

Lifter stud VDI 3366

Lifter stud with cable securing device, with welded disc

2130.11.

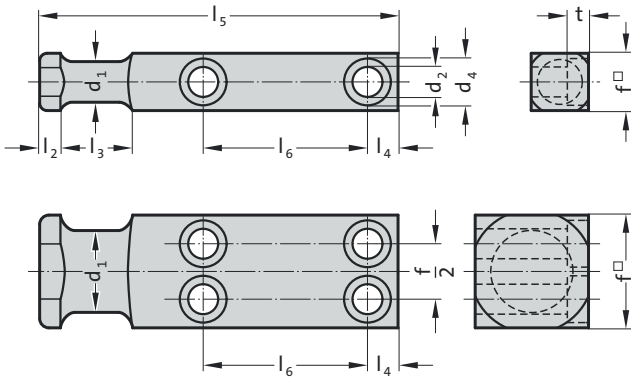

2130.11. Lifter stud VDI 3366



Order No	d ₁	d ₂	d ₄	f	l ₂	l ₃	l ₄	l ₅	l ₆	t	Number of screw holes	Lifting capacity [kg]
2130.11.020	16	9	15	20	6	20	10	80	34	9	2	320
2130.11.025	20	11	18	25	8	25	10	90	37	11	2	630
2130.11.035	25	13.5	20	35	8	30	12	100	38	13	2	1250
2130.11.040	32	17.5	26	40	10	32	16	120	46	17.5	2	2000
2130.11.050	40	22	33	50	10	40	18	140	54	21.5	2	3200
2130.11.060	50	26	40	60	12	45	22	160	59	25.5	2	5000
2130.11.080	63	22	33	80	12	50	20	200	78	21.5	4	8000
2130.11.100	80	26	40	100	15	65	25	250	100	25.5	4	12500
2130.11.120	100	33	48	120	15	80	30	300	125	32	4	20000

2130.12.

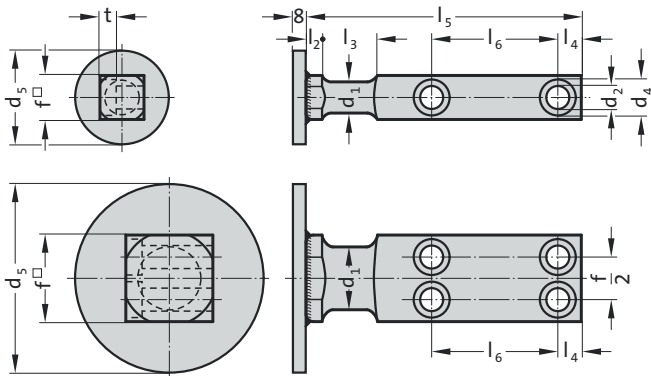

2130.12. Lifter stud with cable securing device, with welded disc



Order No	d ₁	d ₂	d ₄	d ₅ *	f	l ₂	l ₃	l ₄	l ₅	l ₆	t	Number of screw holes	Lifting capacity [kg]
2130.12.020	16	9	15	60	20	6	20	10	80	34	9	2	320
2130.12.025	20	11	18	70	25	8	25	10	90	37	11	2	630
2130.12.035	25	13.5	20	70	35	8	30	12	100	38	13	2	1250
2130.12.040	32	17.5	26	110	40	10	32	16	120	46	17.5	2	2000
2130.12.050	40	22	33	110	50	10	40	18	140	54	21.5	2	3200
2130.12.060	50	26	40	150	60	12	45	22	160	59	25.5	2	5000
2130.12.080	63	22	33	150	80	12	50	20	200	78	21.5	4	8000
2130.12.100	80	26	40	150	100	15	65	25	250	100	25.5	4	12500
2130.12.120	100	33	48	150	120	15	80	30	300	125	32	4	20000

*Pulley for cable securing device welded on