



Electro- mechanical transporters



Electro-mechanical transporters General Information

The FIBRO electro-mechanical transporters have been developed to effectively and inexpensively solve the problems of transporting parts and the removal of stamping and cutting residues from presses.

The principle behind the electro-mechanical transporter is the so-called „table cloth effect“. The slow acceleration during the forward stroke pushes the parts or offcuts forwards. The fast return stroke of the guiding system results in a transport movement in only one direction.

Due to its compact design, the FIBRO electro-mechanical transporter is also suitable for applications where only limited space is available. The simple, sturdy and flexible design provides a safe, reliable, efficient and a cost efficient solution.

Basic advantages:

- compact design
- low maintenance
- low noise level (< 70 dB)

Designs:

- 2299.001 vertical gear position
- 2299.002 horizontal gear position
- 2299.011 vertical gear position,
with profile and support
- 2299.012 horizontal gear position
with profile and support
- 2299.121 vertical gear position,
with two slides, profile and support
- 2299.122 horizontal gear position
with two slides, profile and support
- 2299.221 vertical centre gear position,
two slides, with profile and support
- 2299.222 horizontal centre gear position,
two slides, with profile and support

Technical data:

Drive: Alternating current (3 phases)
1375 min⁻¹
0.09 kW rated capacity
0.51 A nominal current at 400 V
Weight 4.4 kg
Protection class IP55
(DIN EN 60529)

Delivery stroke:
20 mm

Conveying speed:
approx. 4.5m/min

Stroke frequency:
4 strokes/second

max. guiding system weight (incl. profile):
35 kg

max. bulk weight (guiding system weight,
profile, transport items):
100 kg

Temperature range
(permissible ambient temperature):
-20 to +60 °C

Scope of delivery:

The transporters are supplied without connection cable.

Design data (CAD):

2D + 3D CAD data for various CAD systems as well as system-neutral interfaces are available on the internet at:

<http://fibro.partserver.de>



Electro-mechanical transporters
 vertical gear position, two slides, with profile and support
 horizontal gear position, two slides, with profile and support

2299.121.

Direction of conveyance/
 work direction

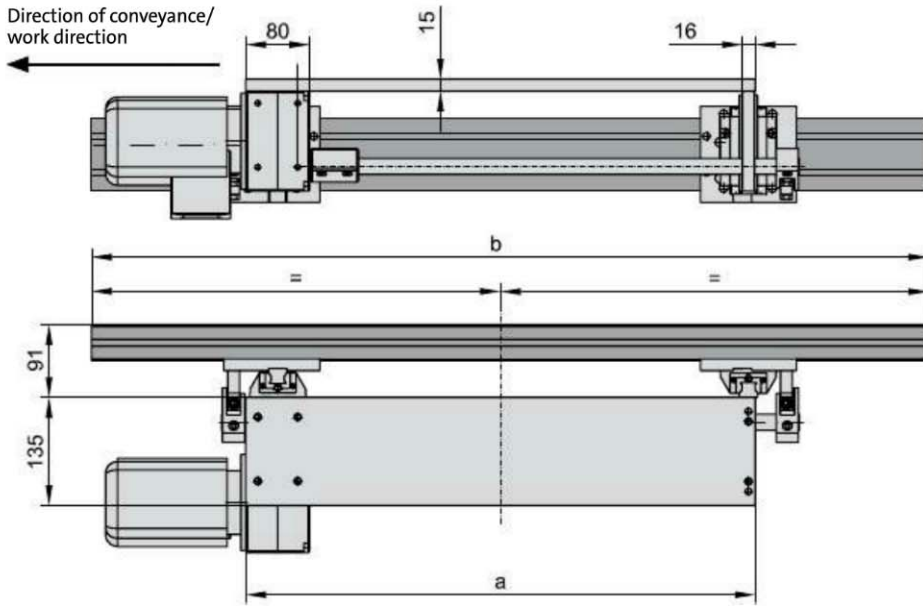

Ordering example:

Transporter	= 2299.
Type 121	= 121.
b = 1400 mm	= 1400.
a = 900 mm	= 0900
Order No	= 2299.121.1400.0900

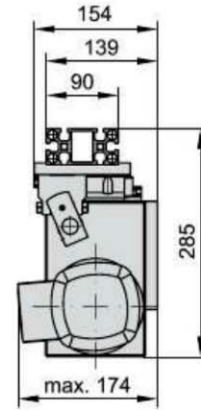

2299.121. vertical gear position, two slides, with profile and support

b	1300	1400	1500	1600	1700	1800	1900	2000	2100	2200	2300	2400	2500	2600	2700	2800	2900	3000	
a	●																		
900	●	●	●	●	●	●	●	●	●	●	●	●	●	●	●	●	●	●	●
1200	●	●	●	●	●	●	●	●	●	●	●	●	●	●	●	●	●	●	●
1500	●	●	●	●	●	●	●	●	●	●	●	●	●	●	●	●	●	●	●

2299.122.

Direction of conveyance/
 work direction

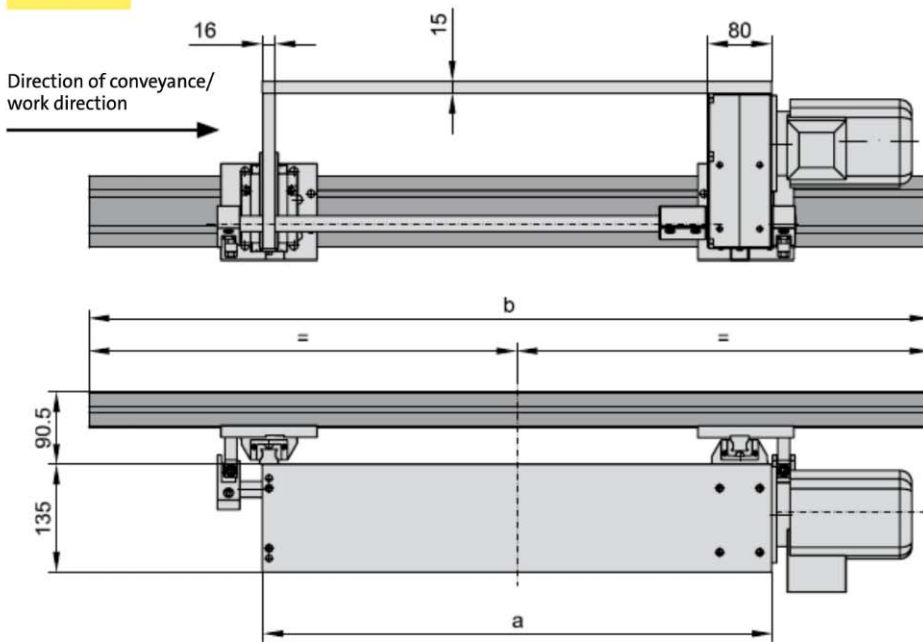

Ordering example:

Transporter	= 2299.
Type 122	= 122.
b = 2200 mm	= 2200.
a = 1200 mm	= 1200
Order No	= <u>2299.122.2200.1200</u>

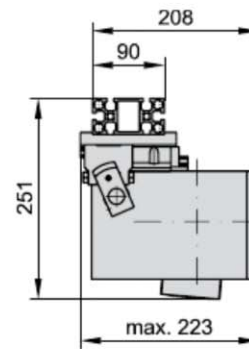

2299.122. horizontal gear position, two slides, with profile and support

b	1300	1400	1500	1600	1700	1800	1900	2000	2100	2200	2300	2400	2500	2600	2700	2800	2900	3000	
a	●																		
900	●	●	●	●	●	●	●	●	●	●	●	●	●	●	●	●	●	●	●
1200	●	●	●	●	●	●	●	●	●	●	●	●	●	●	●	●	●	●	●
1500	●	●	●	●	●	●	●	●	●	●	●	●	●	●	●	●	●	●	●