

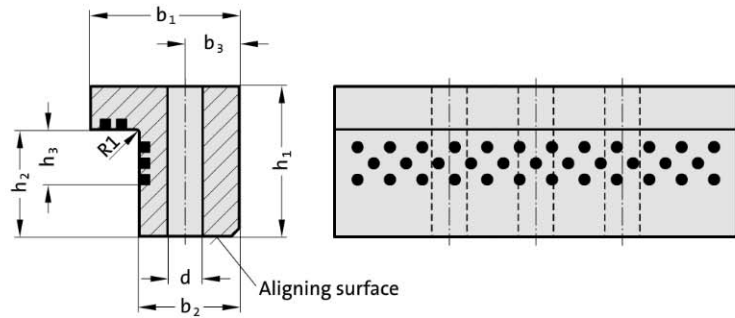

2962.73.

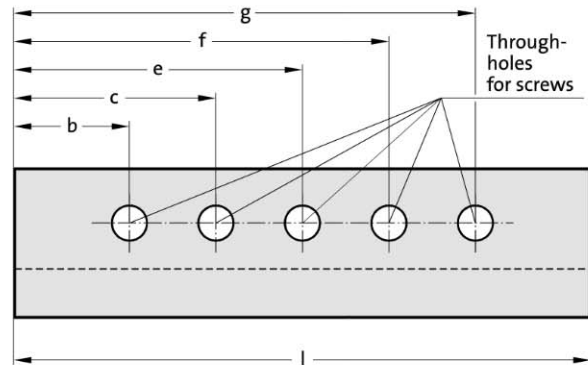

Mounting example

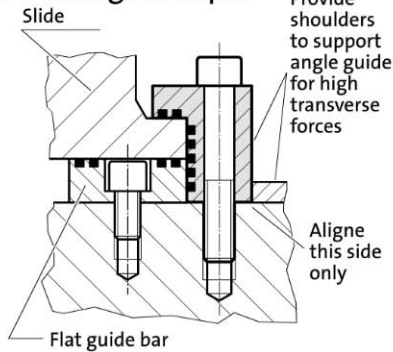

Material:

Bronze with solid lubricant, oilless lubricating

Note:

Screws are not included.

Fixing:

Use socket cap screws DIN EN ISO 4762.

2962.73. Angled guide gib, Bronze with solid lubricant

Order No	b ₁	h ₁	l	b ₂	b ₃	h ₂	h ₃	b	c	e	f	g	d	Number of screw holes
2962.73.025.125	25	15.5	125	18	9	8.5	6	27.5	-	-	-	97.5	9	2
2962.73.025.160	25	15.5	160	18	9	8.5	6	27.5	-	-	-	132.5	9	2
2962.73.032.125	32	30.5	125	22	11	15.5	9	27.5	-	-	-	97.5	11	2
2962.73.032.160	32	30.5	160	22	11	15.5	9	27.5	-	-	-	132.5	11	2
2962.73.032.200	32	30.5	200	22	11	15.5	9	27.5	-	-	-	172.5	11	2
2962.73.045.100	45	50.5	100	30	15	34.5	18	27.5	-	-	-	72.5	13.5	2
2962.73.045.160	45	50.5	160	30	15	34.5	18	27.5	-	-	-	132.5	13.5	2
2962.73.055.100	55	55.5	100	37	20	39.5	23	27.5	-	-	-	72.5	13.5	2
2962.73.055.160	55	55.5	160	37	20	39.5	23	27.5	-	-	-	132.5	13.5	2
2962.73.070.160	70	75.5	160	50	30	55.5	35	35	-	-	-	125	17.5	2
2962.73.070.200	70	75.5	200	50	30	55.5	35	35	-	-	-	165	17.5	2
2962.73.070.250	70	75.5	250	50	30	55.5	35	35	-	125	-	215	17.5	3
2962.73.070.400	70	75.5	400	50	30	55.5	35	35	125	200	275	365	17.5	5
2962.73.085.160	85	90.5	160	63	38	65.5	45	42.5	-	-	-	117.5	22	2
2962.73.085.200	85	90.5	200	63	38	65.5	45	42.5	-	-	-	157.5	22	2
2962.73.085.250	85	90.5	250	63	38	65.5	45	42.5	-	125	-	207.5	22	3
2962.73.085.400	85	90.5	400	63	38	65.5	45	42.5	125	200	275	357.5	22	5