

# COUNTERSINK DEDICATED ROUND DOWN

TOOL CODE B3

4

ORDERING SPECIFICATIONS

Material Type	Thickness "T"	Maximum % Depth "D"
mild steel	≥ .047(1.2) to < .121(3.1)	85%
	≥ .121(3.1) to < .197(5.0)	60%
	≥ .197(5.0)	50%
aluminum	≥ .047(1.2)	85%
stainless steel	≥ .047(1.2) to < .077(2.0)	85%
	≥ .077(2.0) to < .118(3.0)	60%
	≥ .118(3.0)	50%

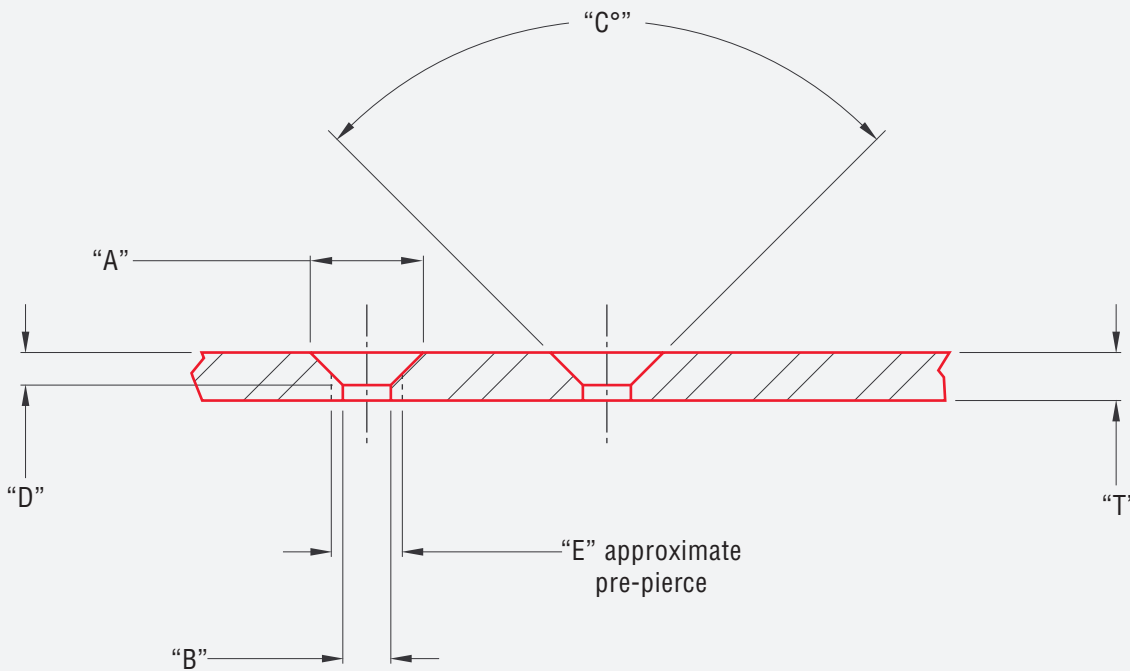

## TOOL INFORMATION

To manufacture a tool to your specifications please provide data for either :

- 1) "A" and "C" dimensions, or
- 2) "A", "B" and "C" dimensions, or
- 3) "A", "C" and "D" dimensions

AØ \_\_\_\_\_ D \_\_\_\_\_

BØ \_\_\_\_\_ EØ \_\_\_\_\_

C° \_\_\_\_\_

## GENERAL INFORMATION

Material Type \_\_\_\_\_

Material Thickness "T" \_\_\_\_\_

Machine Type \_\_\_\_\_

Tooling Style \_\_\_\_\_

Tooling Station \_\_\_\_\_

Dimensions filled in by \_\_\_\_\_

Approved By \_\_\_\_\_

° indicates DEGREES  
Ø indicates DIAMETER



Dimensions in inches (millimeters)