

740 Mounts

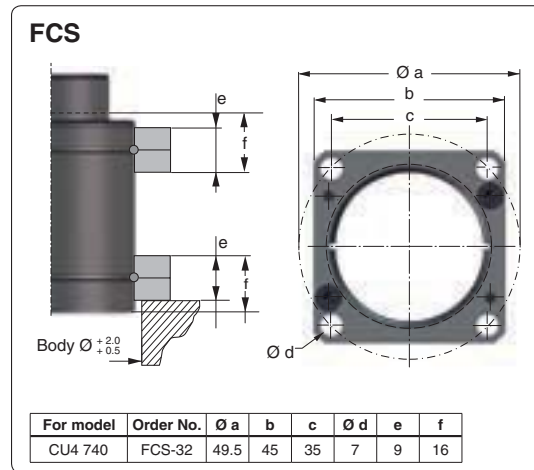

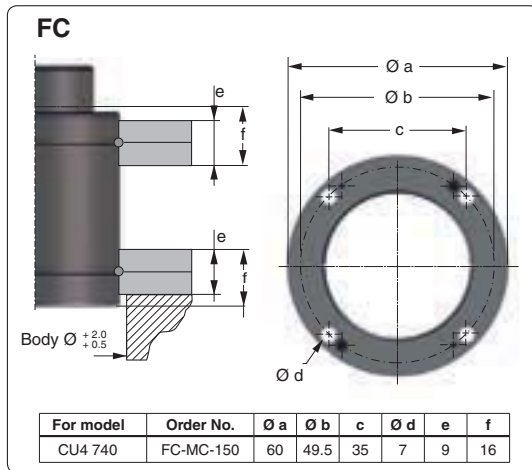

Note! For dimensions on mounting possibility K-500 refer to Chapter 3.

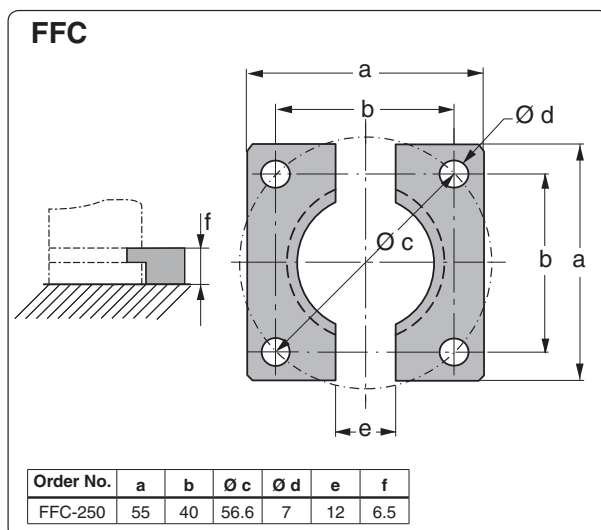
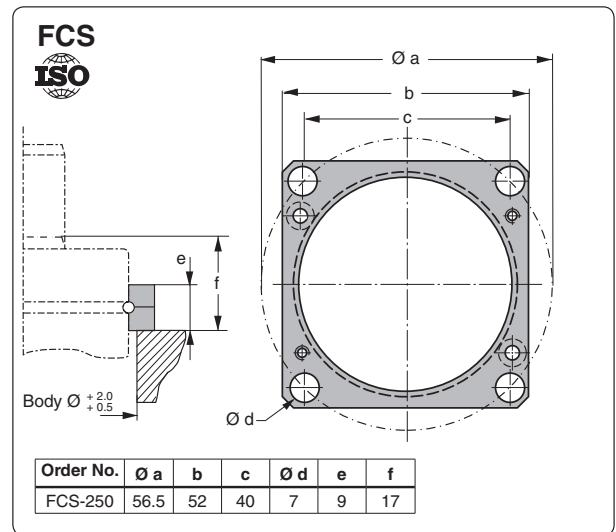
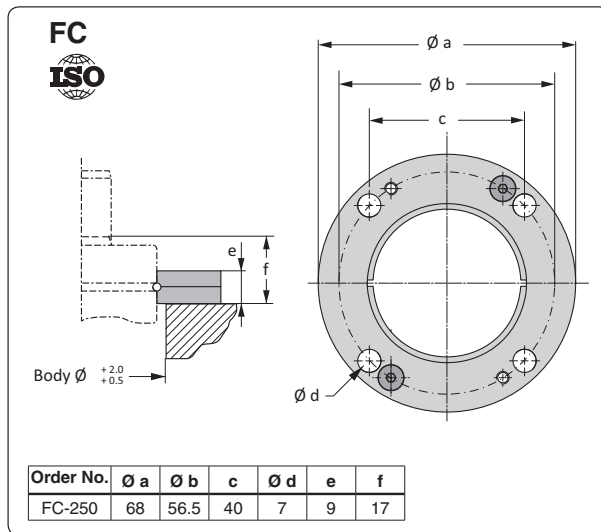
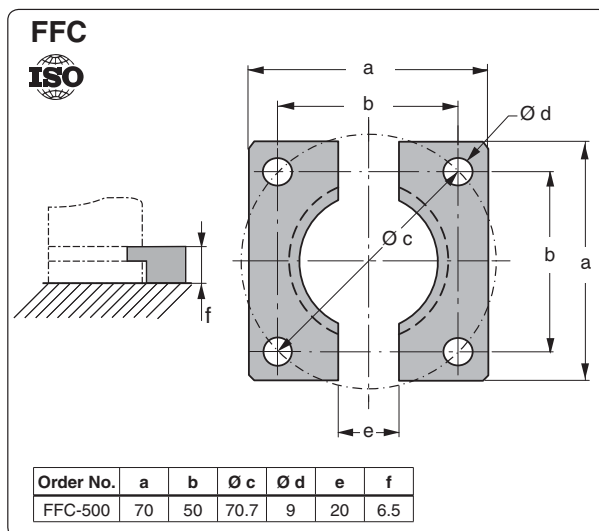
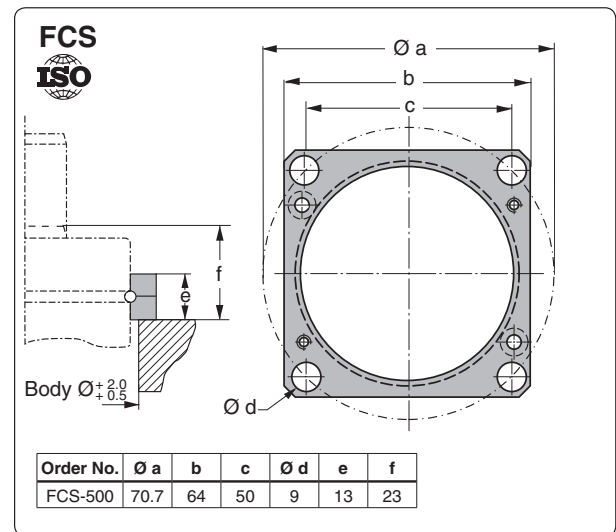
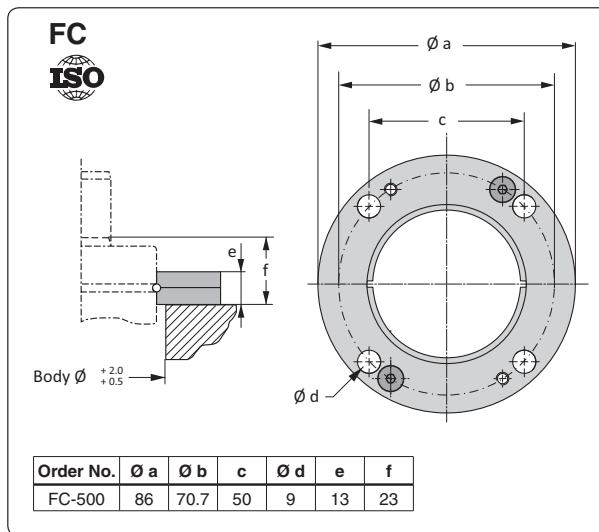

Note! For dimensions on mounting possibility K-500 refer to Chapter 3.

1000 Mounts

MP
ISO

Note! Comes complete with screws to mount gas spring.

Order No.	a	b
MP-750	75	56.5

FC
ISO

Order No.	Ø a	Ø b	c	Ø d	e	f
FC-750	95	80	56.5	9	13	24

FCS
ISO

Order No.	Ø a	b	c	Ø d	e	f
FCS-750	80	70	56.5	9	13	24

FFC
ISO

Order No.	a	b	Ø c	Ø d	e	f
FFC-750	75	56.5	80	9	24	12

S
ISO

Note! Support S is designed to be used in combination with flanges mounted in the U or C groove or attachment B.

The mounting screw (M8) should be tightened with torque 25 Nm.

Order No.	Ø a	b	c	d	e	f	g	Ø h	i	j
S-750	50.4	20	40	40	130	110	10	9	30	20

Note! For dimensions on mounting possibilities K-750, FAC-750, SA-750, HM-750 and FCSC-750 refer to Chapter 3.

2400 Mounts

MP
ISO

Note! Comes complete with screws to mount gas spring.

Order No.	a	b
MP-1500	100	73.5

FC
ISO

Order No.	Ø a	Ø b	c	Ø d	e	f
FC-1500	122	104	73.5	11	16	29

FCS
ISO

Order No.	Ø a	b	c	Ø d	e	f
FCS-1500	104	90	73.5	11	16	29

FFC
ISO

Order No.	a	b	Ø c	Ø d	e	f
FFC-1500	100	73.5	104	11	24	12

S
ISO

Note! Support S is designed to be used in combination with flanges mounted in the U or C groove or attachment B.

The mounting screw (M10) should be tightened with torque 52 Nm.

Order No.	Ø a	b	c	d	e	f	g	Ø h	i	j
S-1500	75.4	22.5	52.5	52.5	160	137	11.5	11	30	20

Note! For dimensions on mounting possibilities K-1500, FAC-1500, SA-1500, HM-1500 and FCSC-1500 refer to Chapter 3.

4200 Mounts

MP
ISO

Note!
Comes complete with screws to mount gas spring.

Order No.	a	b
MP-3000	120	92

FC
ISO

Order No.	Ø a	Ø b	c	Ø d	e	f
FC-3000	150	130	92	13.5	18	33

FCS
ISO

Order No.	Ø a	b	c	Ø d	e	f
FCS-3000	130	110	92	13.5	18	33

FFC
ISO

Order No.	a	b	Ø c	Ø d	e	f
FFC-3000	120	92	130	13.5	24	12

S
ISO

Note! Support S is designed to be used in combination with flanges mounted in the U or C groove or attachment B.

The mounting screw (M12) should be tightened with torque 91 Nm.

Order No.	Ø a	b	c	d	e	f	g	Ø h	i	j
S-3000	95.4	25	67.5	62.5	195	170	12.5	13	30	20

Note! For dimensions on mounting possibilities K-3000, FAC-3000, SA-3000, HM-3000 and FCSC-3000 refer to Chapter 3.

6600 Mounts

MP
ISO

Note! Comes complete with screws to mount gas spring.

Order No.	a	b
MP-5000	140	109.5

FC
ISO

Order No.	Ø a	Ø b	c	Ø d	e	f
FC-5000	175	155	109.5	13.5	21	36

FCS
ISO

Order No.	Ø a	b	c	Ø d	e	f
FCS-5000	155	130	109.5	13.5	21	36

FFC
ISO

Order No.	a	b	Ø c	Ø d	e	f
FFC-5000	140	109.5	155	13.5	24	12

S
ISO

Note! Support S is designed to be used in combination with flanges mounted in the U or C groove or mounting option B.

The mounting screw (M12) should be tightened with torque 91 Nm.

Order No.	Ø a	b	c	d	e	f	g	Ø h	i	j
S-5000	120.4	27.5	77.5	74	220	195	12.5	13	30	20

Note! For dimensions on mounting possibilities K-5000, and FCSC-5000 refer to Chapter 3.

9500 Mounts

MP
ISO

Note! Comes complete with screws to mount gas spring.

Order No.	a	b
MP-7500	190	138

FC
ISO

Order No.	Ø a	Ø b	c	Ø d	e	f
FC-7500	220	195	138	17.5	27	41

FCS
ISO

Order No.	Ø a	b	c	Ø d	e	f
FCS-7500	195	162	138	17.5	27	41

FFC
ISO

Order No.	a	b	Ø c	Ø d	e	f
FFC-7500	190	138	195.2	17.5	24	12

S
ISO

Note! Support S is designed to be used in combination with flanges mounted in the U or C groove or mounting option B.

The mounting screw (M12) should be tightened with torque 91 Nm.

Order No.	Ø a	b	c	d	e	f	g	Ø h	i	j
S-7500	150.4	30	95	100	260	230	15	13	30	20

Note! For dimensions on mounting possibilities K-7500 and FCSC-7500 refer to Chapter 3.