

BALL LOCK RETAINERS

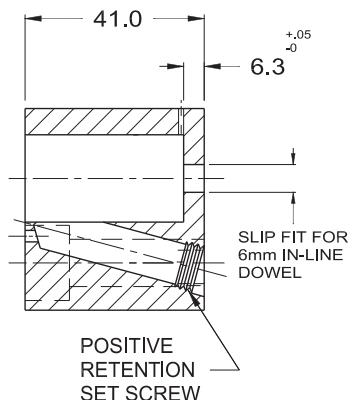

MINI TRUE SET

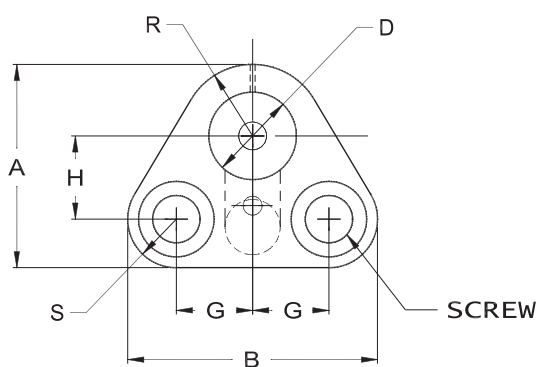

Manufactured under Patent No.'s 0351395, 5357835

FOR ACCESSORIES SEE PAGES 51-52, 62.

Complete design & CAD files visit WWW.MOELLERMCAD.COM

Heavy Duty

CATALOG NUMBER	DIA.	A	B	G	H	R	S	SCREW SIZE
MRM 10	10	37.8	40.6	11.1	19.0	9.5	9.2	M8
MRM 13	13	40.3	47.6	14.3	19.0	11.7	9.5	M8
MRM 16	16	42.1	50.8	15.9	19.0	13.5	9.5	M8
MRM 20	20	46.5	57.1	17.5	19.0	16.4	11.1	M10
MRM 25	25	56.5	65.1	19.8	23.8	20.0	12.7	M12
MRM 32	32	58.2	64.0	19.8	23.8	22.2	12.2	M12
MRM 40	40	67.3	76.2	24.0	27.0	26.0	14.3	M12

SHIM PLATES

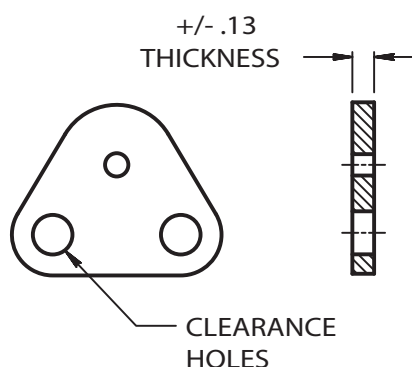

Available Thickness	Ordering Number
3.0	030
6.0	060
10.0	100
13.0	130

CATALOG NUMBER
MAM 10-
MAM 13-
MAM 16-
MAM 20-
MAM 25-
MAM 32-
MAM 40-

INSERT SHIM ORDERING NUMBER

ORDERING EXAMPLE
MAM 16-060