

X 4200

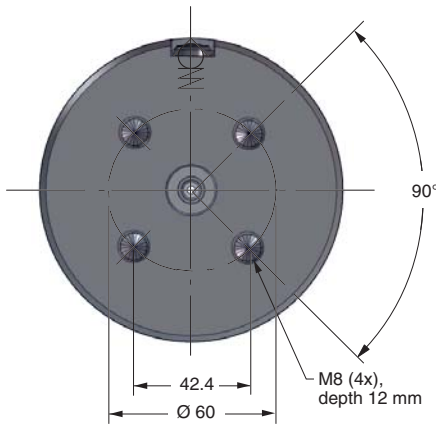
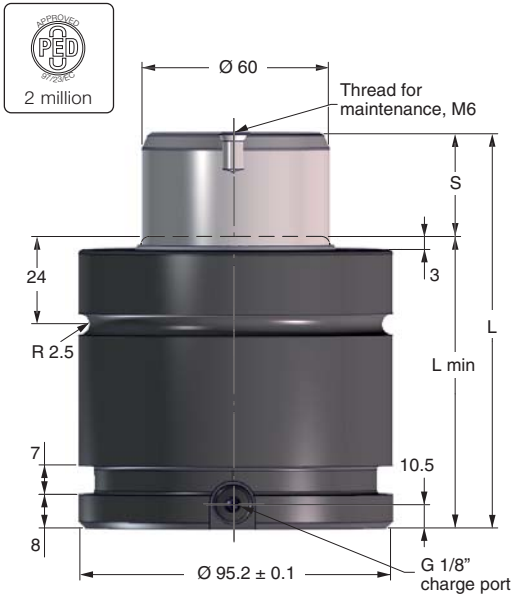

The Power Line Series includes our shortest and most powerful Piston Rod Sealed gas springs, offering impressive force in a very compact format.

These gas springs are available with forces from 1,700 N up to 200,000 N and stroke lengths between 7 and 125 mm.

There is a sideport for gas charging that can also be used to connect to a hose system.

An upper C-groove, lower U-groove together with four M8 threaded holes allow various mounting possibilities using our standard mounts.

Order No.	S stroke	Force in N at 150 bar/+20°C		Force in lbf at 150 bar/+20°C		L ±0.25	L min.	Gas vol. (l)	Weight (kg)
		Initial	End force*	Initial	End force*				
X 4200-016	** 16		61,700		13,870	90	74	0.15	2.81
X 4200-019	19		63,700		14,320	96	77	0.18	2.88
X 4200-025	** 25		60,800		13,670	108	83	0.26	2.96
X 4200-032	32		64,300		14,455	122	90	0.30	3.13
X 4200-038	** 38		65,800		14,790	134	96	0.32	3.28
X 4200-050	** 50	42,000	67,000	9,440	15,060	158	108	0.40	3.57
X 4200-063	** 63		67,800		15,240	184	121	0.49	4.10
X 4200-075	75		68,000		15,285	208	133	0.58	4.20
X 4200-080	** 80		68,600		15,420	218	138	0.61	4.32
X 4200-100	** 100		69,100		15,535	258	158	0.74	4.81
X 4200-125	** 125		69,600		15,645	308	183	0.91	5.42

* = at full stroke

** Recommended stroke length for optimal delivery

Basic Information

For general information see "About gas springs", 2.1
 Pressure medium Nitrogen
 Max. charging pressure 150 bar (at 20°C)
 Min. charging pressure 25 bar (at 20°C)
 Operating temperature 0 to +80°C
 Force increase by temperature ±0.3%/°C
 Recommended max strokes/min ... ~ 30 to 100 (at 20°C)
 Max piston rod velocity 1.6 m/s

Rod surface Nitrided
 Tube surface Black oxide
 Repair kit 3018849

Mounting Possibilities

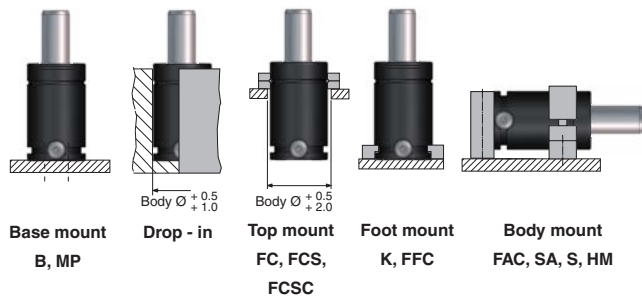

Note! For dimensions on mounting possibilities K-3000, FAC-3000, SA-3000, HM-3000 and FCSC-3000 refer to Chapter 3.

X 4200 Mounts

MP
ISO

Note!
Comes complete with screws to mount gas spring.

Order No.	a	b
MP-3000	120	92

FC
ISO

Order No.	Ø a	Ø b	c	Ø d	e	f
FC-3000	150	130	92	13.5	18	33

FCS
ISO

Order No.	Ø a	b	c	Ø d	e	f
FCS-3000	130	110	92	13.5	18	33

FFC
ISO

Order No.	a	b	Ø c	Ø d	e	f
FFC-3000	120	92	130	13.5	24	12

S
ISO

Note! Support S is designed to be used in combination with flanges mounted in the U or C groove or attachment B.

The mounting screw (M12) should be tightened with torque 91 Nm.

Order No.	Ø a	b	c	d	e	f	g	Ø h	i	j
S-3000	95.4	25	67.5	62.5	195	170	12.5	13	30	20

Note! For dimensions on mounting possibilities K-3000, FAC-3000, SA-3000, HM-3000 and FCSC-3000 refer to Chapter 3.